



CITY OF COURTENAY

Building Division
830 Cliffe Avenue
Courtenay, BC V9N 2J7
Tel: 250-703-4862 Email:
building@courtenay.ca

Guide to Residential Deck Construction

GENERAL INFORMATION

Decks are structures and, therefore, must comply with both the current BC Building Code and applicable City of Courtenay regulations and bylaws. A building permit is required for a new deck or for changes to structural elements, guards and railings of an existing deck. Other permits may be required depending on the setbacks (as laid out in the Zoning designations for the property); the first step is to check the zoning of your property.

Zoning specifies the required *minimum* setbacks from the deck to the property lines and the maximum allowable lot coverage (this is the total footprint of all structures, including but not limited to homes, decks and accessory buildings (such as sheds, detached garages, etc). Zoning information can be found at the City of Courtenay's website at www.courtenay.ca under the Development Services Department tab. It is important to review the Zoning for the property because this will determine whether your proposed project will receive approval from the City of Courtenay.

REQUIRED SUBMISSIONS AT APPLICATION STAGE

- A completed building permit application
- Two (2) sets of construction drawings (must be double line drawings to scale) showing the deck's compliance with BC Building Code and including site plan, cross-section and floor plan
- Application fee

PLAN DETAILS

Plans for residential decks must show:

- All dimensions
- Footing sizes, post size and spacing
- Sizing of all structural elements and spans
- Flashing details at house connection
- Decking (solid surface deck *must* meet code requirements for roof
- Guards, stairs and handrails
- Any additional information pertaining to your project

INSPECTIONS

Once your permit has been issued, you may then start construction. When you pick-up your permit, you will be given a building permit package that must be kept at the building site for all inspections.

Inspections required for deck construction are generally:

- Footings/Foundation – prior to pouring concrete
- Framing – prior to covering any structure
- Final – when all guards, stairs and handrails are complete

Inspections require at least 24 hour notice: during peak seasons, the daily inspections can fill up quickly so ensure that you are requesting your inspection well ahead of time. Inspections times can be booked Monday to Friday, morning or afternoon. We do not provide an exact time that the inspection will occur but the inspectors will be out between 9:30am and 11:30am in the morning and 1:30pm and 4:00pm in the afternoon. You can book inspections by calling the Building Division at **250-703-4862** or by email **building@courtenay.ca**.

EXAMPLE SITE PLAN

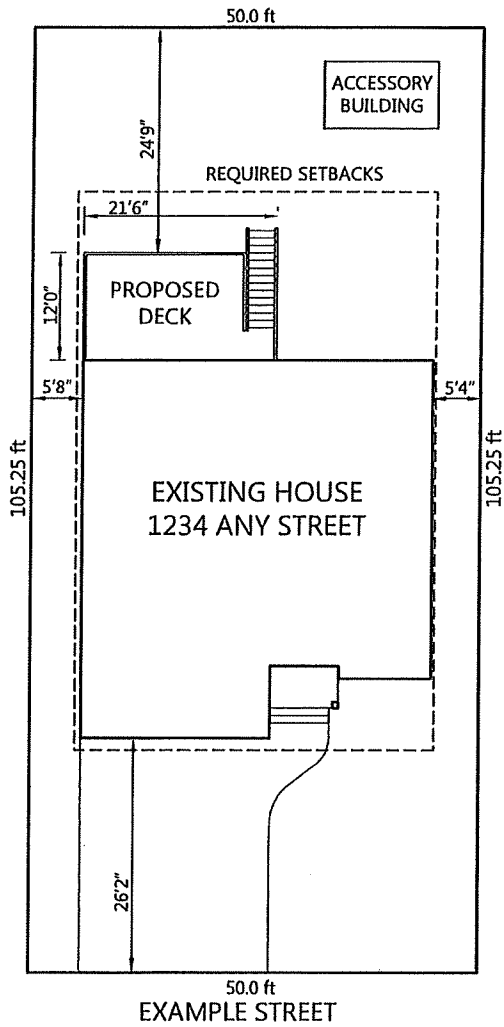

EXAMPLE CROSS SECTION

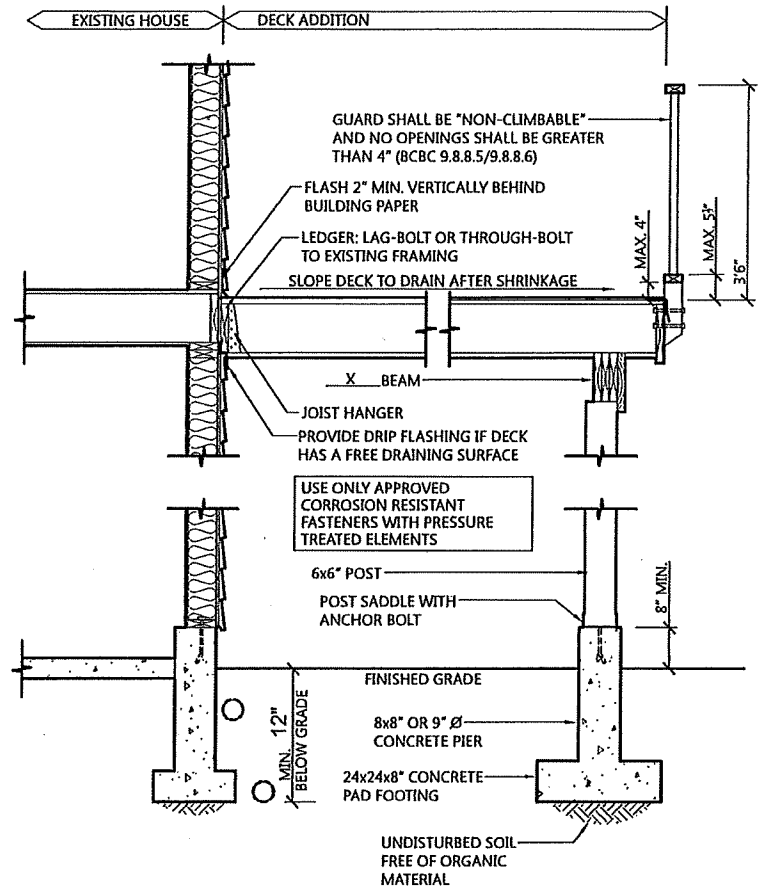

EXAMPLE FLOOR PLAN

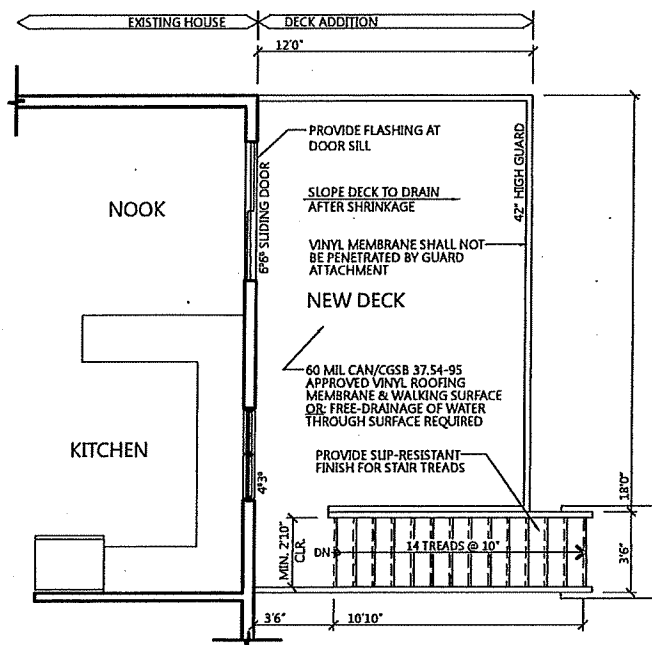

EXAMPLE FOUNDATION PLAN

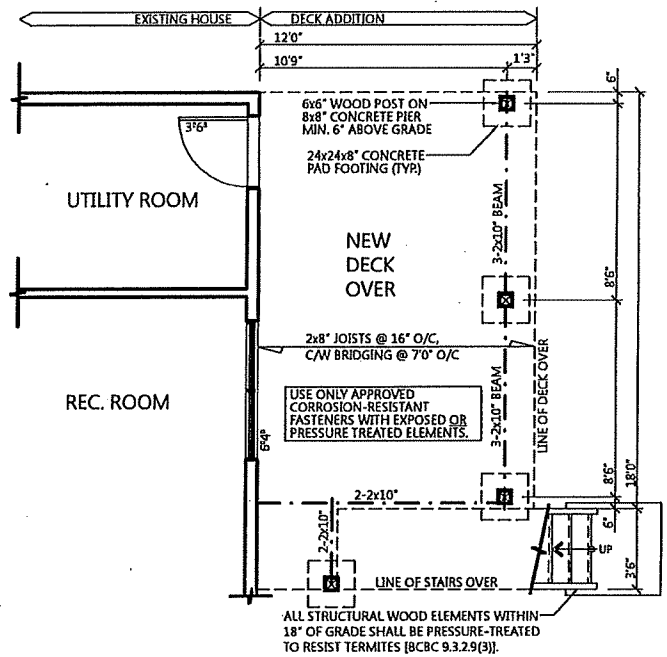

Sample Residential Deck Design and Plan Requirements

B.C.B.C. 2012

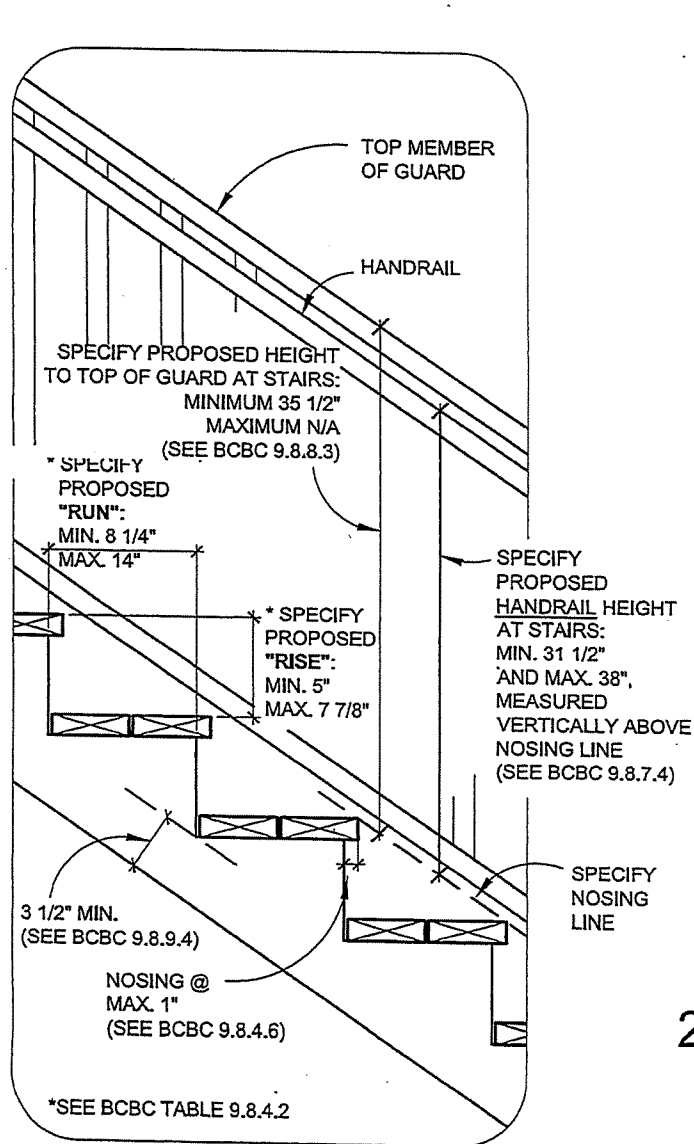

1. Sample Stair & Stringer Detail

(*BC BUILDING CODE 2012)

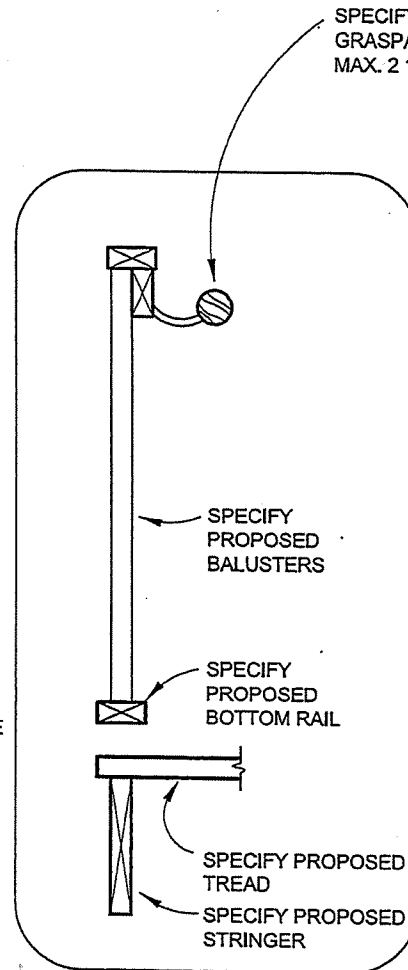

2. Sample Guard & Handrail Section at Stairs

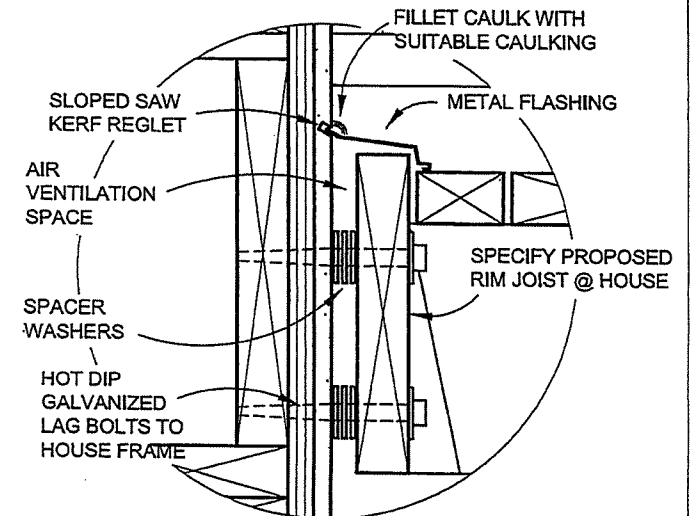

3. Sample Flashing Detail at Intersection of Deck and Existing House

Sample Residential Deck Design and Plan Requirements (Serving an Existing Single Dwelling Unit)

B.C.B.C. 2012

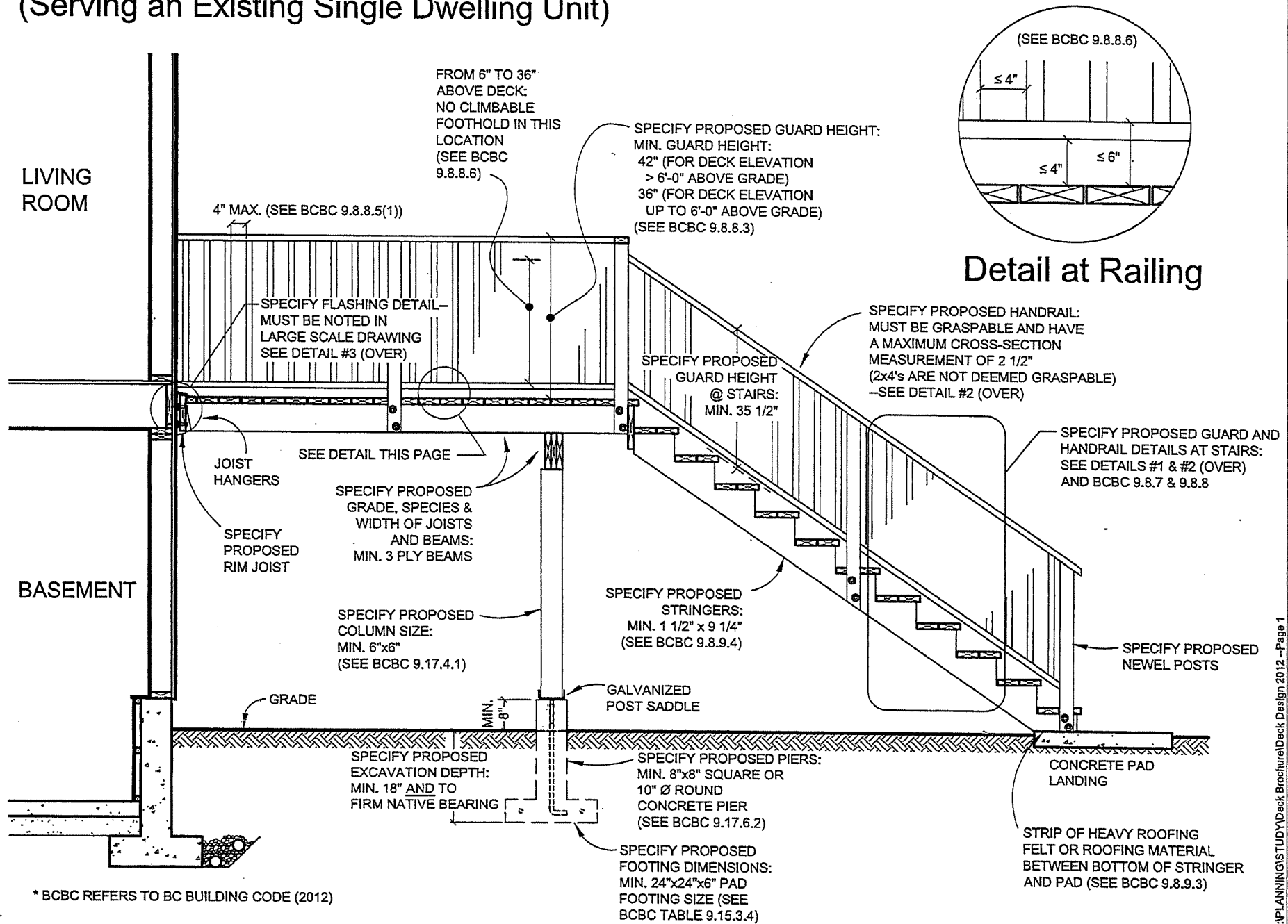

* BCBC REFERS TO BC BUILDING CODE (2012)